

CAD FILE:

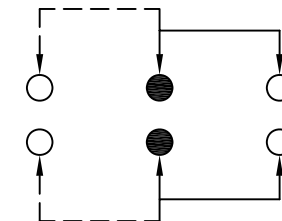

**SCHEMATIC (NON-SHORTING)**

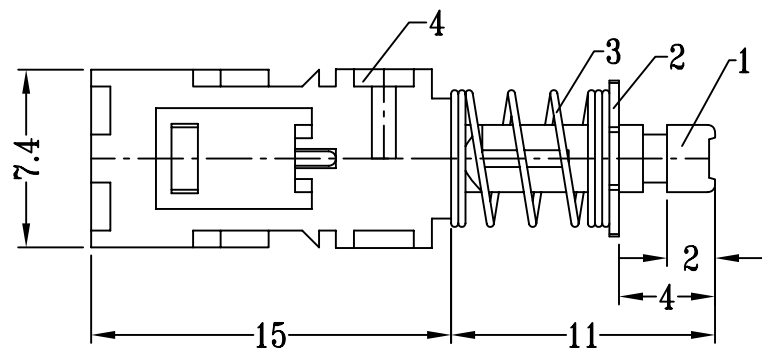
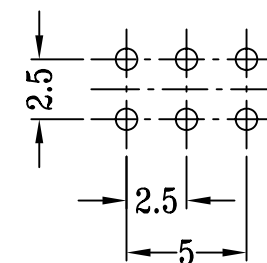
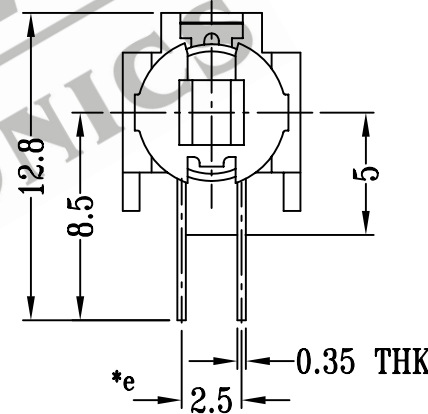
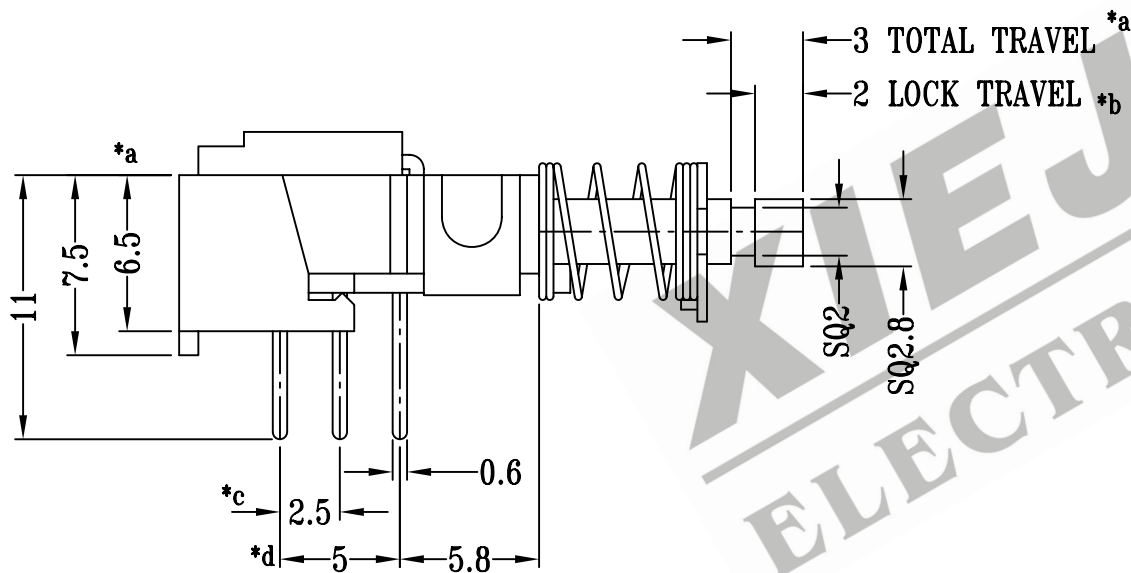

**P.C.B LAYOUT**

注:带\*表示关键尺寸(5个)

NO.	PART NAME	MATERIAL	Q'TY	FINISHING
9	CONTACT CLIP	PBS	2	Ag CLAD
8	CAM STICK	BRASS WIRE	1	NATURAL
7	BASE	PHENOLIC RESIN	1	NATURAL
6	TERMINAL	BRASS STRIP	6	Ag PLATED OVER Ni PLATED
5	SPRING PLATE	PBS STRIP	1	NATURAL
4	HOUSING	PC	1	BLACK
3	SPRING	STAINLESS STEEL	1	TEMPER
2	BLOCK	STEEL STRIP	1	Ni PLATED
1	KNOB	POM	1	BLACK

TOLERANCE UNLESS SPECIFIED		SHENZHEN XIEJIA ELECTRONICS CO.,LTD.			
WITHIN: 1.5±0.1mm OVER : 1.5±0.2mm					
ISSUE	DATE	DESCRIPTIONS		APPD.	
TITLE : PLASTIC PUSH SWITCH		UNIT : MM	DRWG NO.: XJ-DR-PBS22D01-00		
MODEL: PBS-22D01		SCALE: 3:1	DWN.	ZHOUYU	2000-3-16
ALL MATERIALS MUST BE COMPLIANT TO ROHS			CHK'D	FANGYING	2000-3-16
			APPD.	KANGXINAN	2000-3-16